

HP299 FlowKit datasheet

HP299-00-1



Contents

About this document	2
General information	3
Board layout	4
Detailed Operation	5

Appendix 1 Circuit diagrams

About this document

This document concerns the FlowKit in-circuit debugging tool for Flowcode.
The order code for this product is HP299.

1. Trademarks and copyright

PIC and PICmicro are registered trademarks of Arizona Microchip Inc.
AVR is the registered trademarks of the Atmel Corporation.
ARM is the registered trademarks of ARM plc.
E-blocks, Flowcode and FlowKit are trademarks of Matrix Multimedia Limited.

2. Other sources of information

You can find further information on this product and the E-blocks range on the Matrix web site:
www.matrixmultimedia.com.

3. Disclaimer

The information in this document is correct at the time of going to press. Matrix Multimedia reserves the right to change specifications from time to time. This product is for development purposes only and should not be used for any life-critical application.

4. Technical support

If you have any problems operating this product then please refer to the troubleshooting section of this document first. You will find the latest software updates, FAQs and other information on our web site:
www.matrixmultimedia.com

If you still have problems please visit our user forums at: www.matrixmultimedia.com/mmforums/

General information

What does it do?

The FlowKit can be connected to hardware systems to provide a real time debug facility where it is possible to step through the Flowcode program on the PC and step through the program in the hardware at the same time. This function is available with Flowcode 4.2 or later.

Benefits

- A fast way to solve programming problems
- Seamless program and debug

Features

- Compatible with a variety of hardware systems including PICmicro and AVR E-blocks boards
- Compatible with ECIO, MIAC and Formula Flowcode systems via the USB lead
- Allows start, step, and play of programs
- Allows users to see and alter variable values
- Compatible with third party hardware

Description

Whilst Flowcode simulation allows debug of a system to a first pass, FlowKit takes debug to a new level by running the program in the hardware and on the screen at the same time. The system is controlled from within the Flowcode environment where controls allow users to start, stop, pause and step through their program one icon at a time. Under user control the Flowcode software shows the location of the program in the flow chart, the value of all variables in the program, and allows users to alter the variable values when the program is paused.

The package includes the main FlowKit board, an E-blocks connection board, a 10 way IDC ribbon cable, and a USB lead.

Board layout

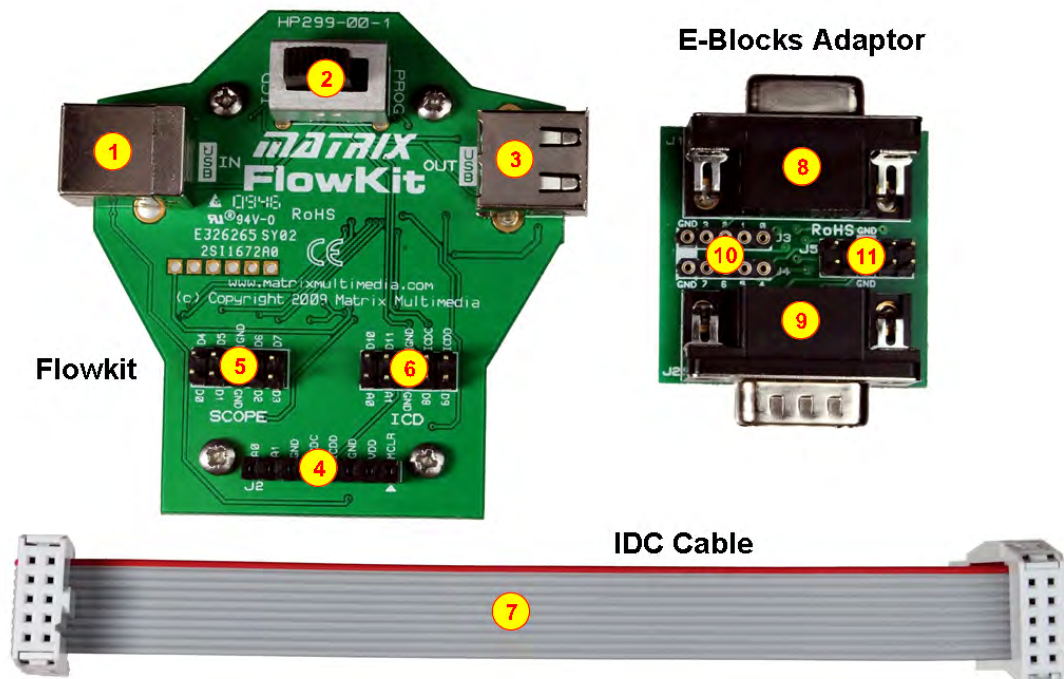

HP299-74-1.cdr

- 1) USB in socket
- 2) Programming / Debugging functionality selection switch
- 3) USB out socket
- 4) Single pin in circuit debugger and analog scope connections
- 5) 10-way scope E-Block Molex connector
- 6) 10-way in circuit debugger and scope Molex connector including analog scope pins
- 7) 10-way IDC cable
- 8) Upstream E-Blocks Connector
- 9) Downstream E-Blocks Connector
- 10) IDC connector
- 11) Single pin connector

Detailed Operation

1. The functionality switch

There is a single large switch on the FlowKit device that controls the overall operation of the device. The switch has two positions marked ICD and PROG. When the switch is in the ICD position the USB cable from the PC is routed to the microcontroller on board the FlowKit device. This allows Flowcode to communicate with the device, which in turn communicates with the development microcontroller via two ICD signals. These two ICD signals carry the data and clock required to drive the ICD and are marked on the boards as ICDD and ICDC.

When the switch is in the PROG position the USB bypasses the FlowKit board and is passed directly through into the USB out. This allows devices such as the Formula Flowcode, the MIAC, ECIOs and the Locktronics PIC to be reprogrammed and debugged without having to remove cables. As an added feature when the switch is placed back into the ICD position the USB out cable can be used to transfer the ICD signals to the afore-mentioned devices.

2. The ICD operation

The in-circuit debugger (ICD) operation is driven from within the Flowcode software (version 4.2 onwards). The ICD feature is activated in Flowcode by going into the Project Options window and ticking the box labeled ICD Mode. This then allows some other options to become available.

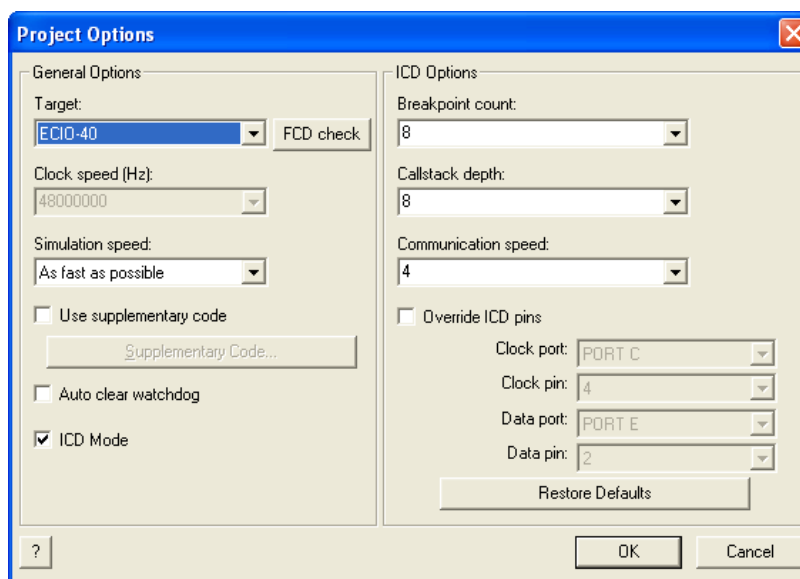

In this dialogue screen:

- The breakpoint count specifies the maximum number of individual breakpoints you can set in your program.
- The callstack depth specifies the maximum stack depth of your program. This should remain at 8 unless you are using the BoostC software stack or a target device with a small or custom hardware stack.
- The communications speed is the amount of time the ICD will wait for communications. If you experience any problems with the ICD communication then you can try upping this value slightly.
- The override ICD pins allows you to define the pins on the target for use by the ICD. When using the EB006 these pins are locked to the default programming pins, normally RB6 and RB7.

- Once you have selected the ICD mode tick box you can compile your project, and program your device. When you have done this, the device will wait at the start of the program until it is told to begin.

The LEDs on the bottom of the FlowKit device indicate the status of the ICD operation:

LED Activity	ICD Status
Solid	ICD is currently disabled / Target is stopped
Pulsing (rapid)	ICD is active & Target microcontroller is running
Pulsing (slow)	ICD is active & Target microcontroller is paused

3. The ICD Connections

The FlowKit tool is capable of connecting to a multitude of different devices. This section explains the different connections and their usage.

1. USB Out Socket

The USB out socket is used for communicating with Matrix PICmicro products that contain a USB boot loader (MIAC, Formula Flowcode, ECIO). When the FlowKit switch is in the PROG position the FlowKit is bypassed and the USB In is connected directly to the USB out. This allows users to reprogram devices without having to connect and disconnect USB cables.

2. Molex header and adapter board

The Molex headers and adapter board provide a means of connecting to an E-Blocks system. There are two double row Molex headers on the FlowKit. One contains the in-circuit debug pins, the analog scope pins and 4 digital scope pins (not implemented in software). The second Molex header provides 8 digital scope pins. The adapter board can simply be used to interface to an upstream programmer board or can be used in between an upstream programmer and a downstream E-Block. The adapter board connects to the FlowKit via a 10-way IDC cable that is supplied with the product.

3. Single Pin Wire Connections

The third connector on the FlowKit provides a means to connect to any other third party hardware. The connector allows the in-circuit debug pins and the analog scope pins to be freely allocated to any pin on your target system. The connector also provides 5V and ground connections which may also need to be connected to allow the in-circuit debug or analogue connections to work correctly. Microchip PICKit compatible boards, such as the low pin count demo board, can be powered and debugged by simply plugged the 6-way header directly into this socket.

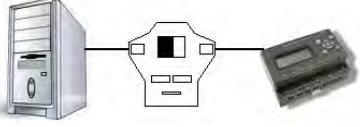
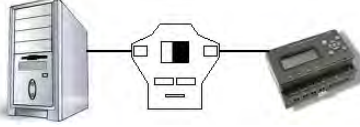
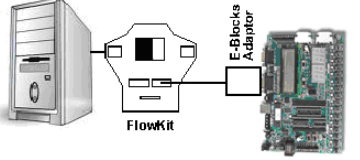
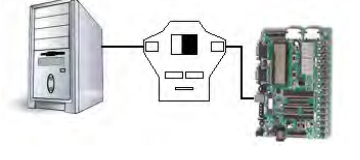
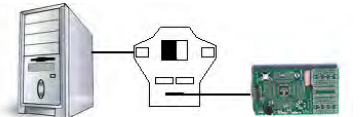
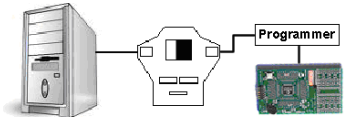
Connection Type	Product	ICD Connections	Programming Connections
1	Matrix USB MIAC ECIO Formula Flowcode Locktronics PIC		
2	E-Blocks HP488 - Dev EB006 - PIC EB019 - AVR EB185 - ARM EB061 - ECIO		
3	3rd Party Microchip Atmel Etc...		

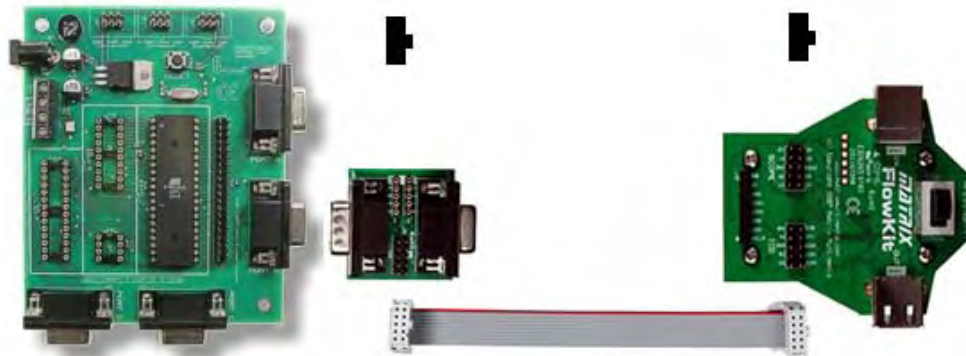

Diagram showing the orientation of the IDC cable for the E-Blocks adapter board

4. Troubleshooting the ICD

If your ICD is not starting correctly then here are a few things for you to try:

- If the Flowcode program changes at all then a small star will appear next to the program name on the title bar. This means that the program requires saving and also means that you will have to recompile and program your device before ICD operations can be resumed.
- The ICD pins must be completely untouched by your program to allow the communications to work correctly. For example if you are using an output or an input icon in your program that is on the same port as the ICD pins then you must use the pin masking to ensure that the ICD pins are untouched.
- If you are using the FlowKit tool then make sure that the ICD pins defined in Flowcode are appropriate for your connections.

- If you are using a USB cable in the USB out socket of the FlowKit and you are using a target other than the type 1 targets listed above then you will need to disconnect this USB cable from your device before the ICD will work.
- Check your target device configuration settings. If the program does not run with ICD disabled then it will not work with ICD enabled.
- If any additional hardware is connected to your ICD pins try disconnecting it and trying again. A large pull up current or a short to another signal source will cause the ICD functionality to fail.
- Unplug the USB cable to the FlowKit ICD tool, reset the target device and then re-insert the USB and try running the ICD again.

5. Installing the Drivers

1. Download the latest drivers from the drivers page on the www.matrixmultimedia.com website:
www.matrixmultimedia.com/eblock_datasheets.php
2. Depending on your operating system open the appropriate file
 - For 32-bit operating systems - dpinst_x86.exe
 - For 64-bit operating systems - dpinst_amd64.exe or dpinst_ia64.exe



3. Click Next



4. Click Accept and then click Next
5. There may be a warning displayed for newer operating systems stating that Microsoft has not tested the device. If this appears then click Yes: install anyway.



6. Click Finish

Appendix 1 – Circuit diagram

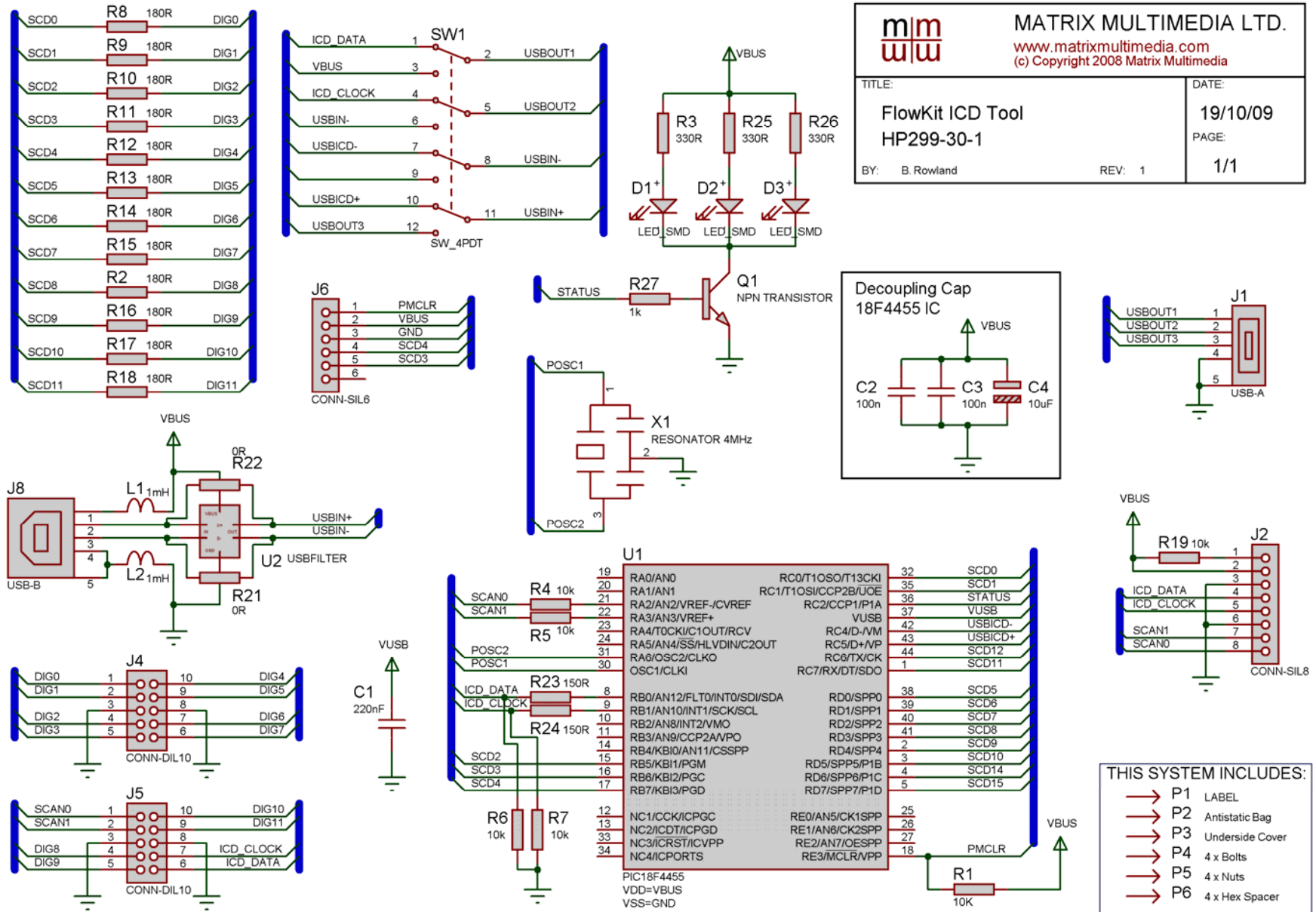

Appendix 1 – Circuit diagram

THIS SYSTEM INCLUDES:-

- L1 LABEL
- L2 Antistatic Bag
- P1 10-way ICD Cable

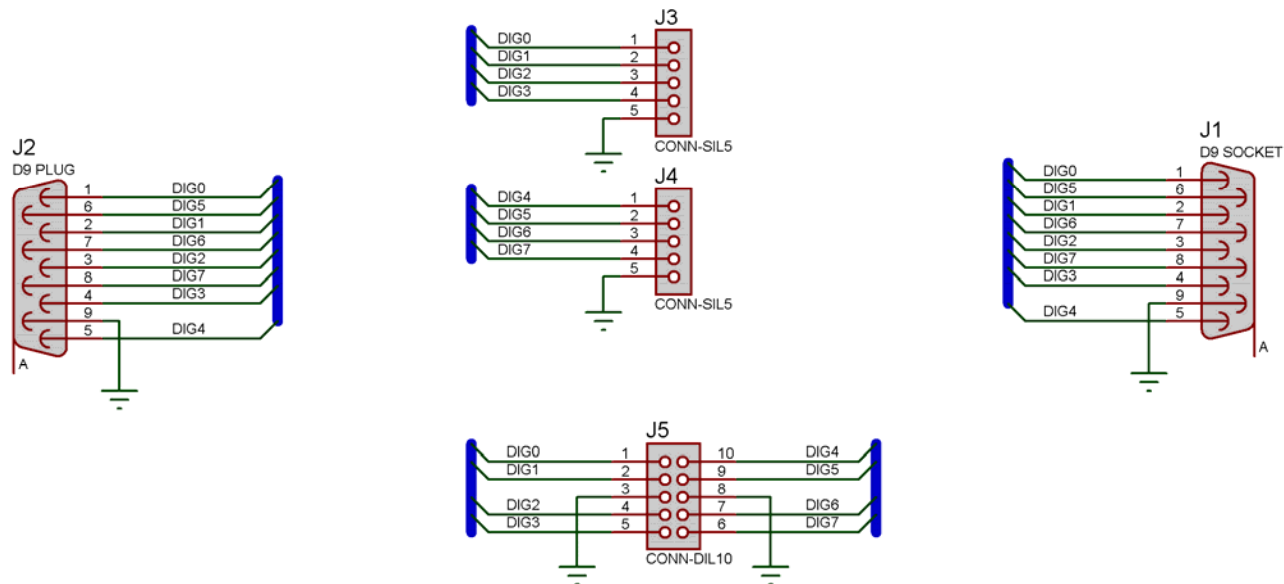

		MATRIX MULTIMEDIA LTD. www.matrixmultimedia.com (c) Copyright 2006 Matrix Multimedia	
TITLE:		DATE:	
Scope E-Block		25/06/09	
BY: B. Rowland		PAGE:	
REV: 1		1/1	